

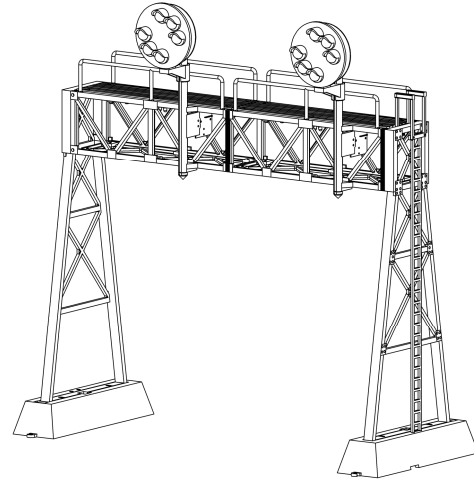

Z-Stuff for Trains
Making model railroading more fun



DZ-1090G Instructions

The G-Gauge signal bridge only needs a 9V battery installed in its base. Alternately, the RED wire connects to power (12-20V AC or DC) and the BLACK wire connects to common. Place the signal over the tracks. As the train passes under the signal bridge, the train is detected by sensors looking down on the tracks. When the train passes under the signal bridge, the indication will change to RED or "stop" and hold until the train has passed. After the train passes and after the selected time delay of either 5 or 10 seconds, the signal will change to YELLOW or "caution". Then, after another 5 or 10 more seconds, it will change back to GREEN or "clear". There is a power switch on the base to turn off the battery and extend operating time. The signal only needs power to operate, but it does have an input wire for each track to provide additional possibilities.

The signal bridge delay time for the change from stop to caution and from caution to clear can be set by the user. There is a slide switch on its circuit board mounted under the signal bridge deck. (See below). To change the delay, slide the switch handle to the desired delay.

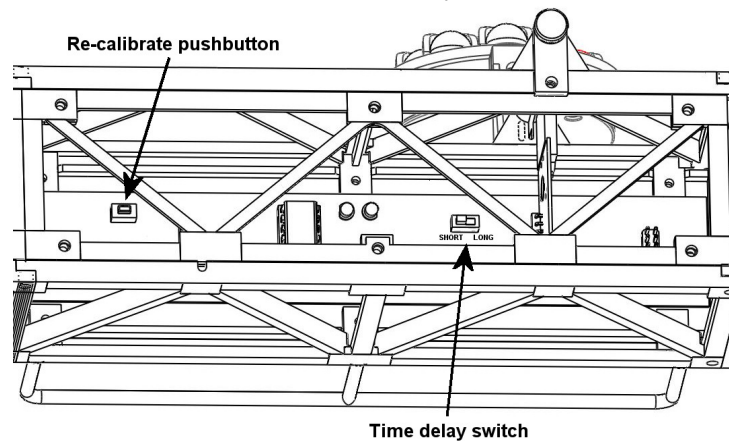

OPTION – If the output wire of a signal (or isolated rail) down-track is connected to one of the input wires of the signal bridge, the signal for that track input will hold on stop until the down-track signal is clear, then the signal bridge signal will cycle back to clear.

Wire Colors and Functions (For the first four (4) tracks.)

RED - Power

BLACK - Common (can be and for isolated rail input, needs to be connected to track common)

INPUTS:

WHITE	Track 1 (closest to ladder)
YELLOW	Track 2
GREEN	Track 3 (Does not apply for 2 track bridge)
BLUE	Track 4 (Does not apply for 2 or 3 track bridge)

Wire Colors and Functions (For tracks 5-8, if present)

RED - Power

BLACK - Common (can be and for isolated rail input, needs to be connected to track common)

INPUTS:

WHITE	Track 5 (closest to ladder)
YELLOW	Track 6
GREEN	Track 7
BLUE	Track 8

A signal bridge for more than 4 tracks will have a second connection for power and input wires.

See back of sheet for dimensions and RE-CALIBRATION directions

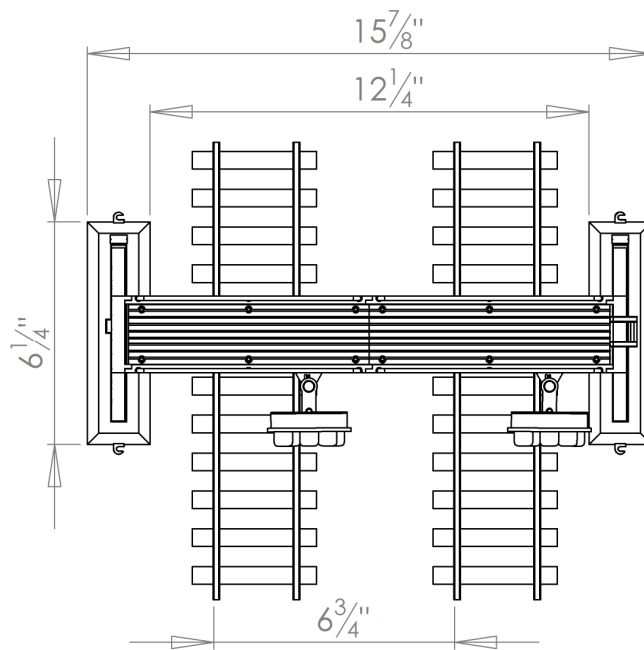

Track centers and bridge side dimensions

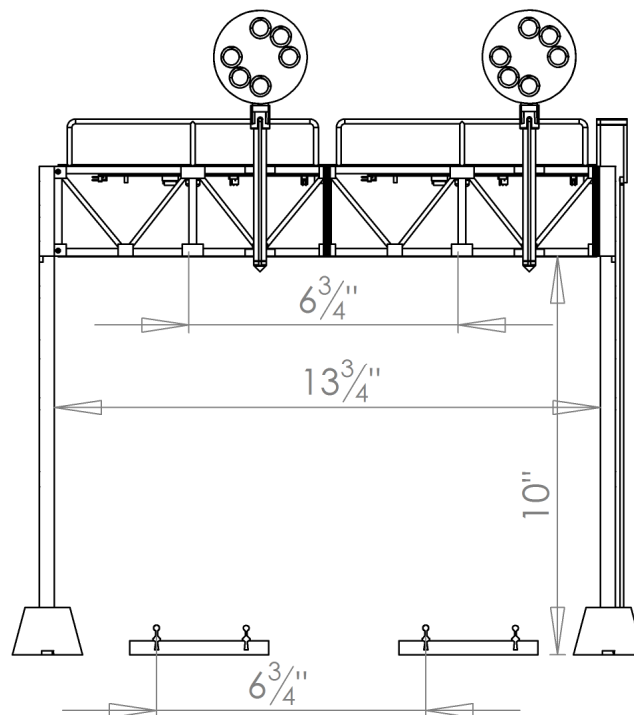

Typical Vertical Clearances

Re-Calibration - if needed

If the sensors of the signal bridge are not doing a good job of detecting trains or if when you place the signal bridge over your tracks and turn on power it does not go to "GREEN" or "CLEAR", you may need to have it re-calibrate itself. (It was factory calibrated and tested.) This is done by simply pressing the "Re-calibrate" switch (shown in the drawing) for one or both tracks as needed. The lighted signals will go to caution (diagonal or YEL) and after 30 secs. or so they will flash. The semaphore will go to YEL at 45 degrees and then cycle to RED and back to YEL. Then, all signals should go to "GREEN" or "CLEAR". (the 7-light Pennsy will be YELLOW vertical).

Since the DZ-1090 signal Bridge is modular, any bridge can be modified to add tracks or signals. For custom versions, please contact ZStuffExpress at www.zstuffexpress.com or 708-352-9105.

For any technical questions you can contact Z-Stuff at www.z-stuff.net or 585-377-0925.